



Helmut Neidel, DL 1 IN

## 5.7 GHz ATV CONVERTER

**The 200 MHz wide 6-cm. amateur radio band in the 5.7 GHz range offers ideal conditions for narrow-band and broad-band transmissions. One type of transmission of this nature is the ATV mode, for which a down-converter to the SAT intermediate frequency is described here.**

- Transmission amplification: App. 40 dB
- Image attenuation: App. 50 dB
- Operational voltage/current: 10-12V/0.26 A
- IN connection: SMA jack
- OUT connection: SMC jack

---

### 1.

#### INTRODUCTION

---

To receive ATV signals at 5.7 GHz a converter is needed which converts the whole of the 6-cm. band into the range of the normal SAT intermediate frequency. Any standard commercial SAT receiver can then be used.

The technical data of the 5.7 GHz ATV converter are:

- Input frequency: 5.65-5.85 GHz
- Output frequency: 1.4-1.6 GHz
- Noise factor: < 1 dB

In the planning phase, the question of a suitable oscillator was bound to come up. Layouts with ceramic resonators (coax or DRO) often founder on the rocks because of obtaining these components, particularly in small numbers. The use of a crystal oscillator, as in narrow-band converters, creates undesirable harmonics in the 200 MHz wide intermediate-frequency and reception range. The use of SAW resonators offers an interesting alternative. They have outstanding characteristics, but are, of course, available only in a few fixed frequencies. A frequency of 423 MHz was selected, which does not cause harmonics either in the reception range or in the interme-



diate frequency range.

The SAW oscillator also has very little phase jitter, which is comparable only with good crystal oscillators. Only the temperature stability is lower than for a real crystal.

## 2.

### CIRCUIT DESCRIPTION

The circuit of the ATV converter for 5.7 GHz is shown in Fig. 1, including the internal voltage regulator.

The circuit consists of a 3-stage amplifier, a sub-harmonic mixer and the SAW oscillator.

Immediately next to the high-frequency input there is a short-circuited  $\lambda/4$  line for protection against static charges

on the aerial cable.

The first two amplifier stages are each equipped with an NEC HEMT (type NE 32584), which creates a noise factor less than 1 dB. The subsequent amplifier, with an ERA-3 from Mini Circuits, balances the attenuation of the 5.7 GHz filter (image frequency) and the mixer.

An HP double diode (type HSMS 8202) acts as a sub-harmonic mixer. Together with the filter input resistances, the conduction components on the mixer create the impedance conditions required for the mixing diodes.

Even while the printed circuit board was being developed, appropriate matching structures were provided. Thus, together with its connecting line, the 5.7 GHz filter branch forms a  $\lambda/4$  component for 2.1 GHz, while with its feed to the double diode the LO filter supplies a

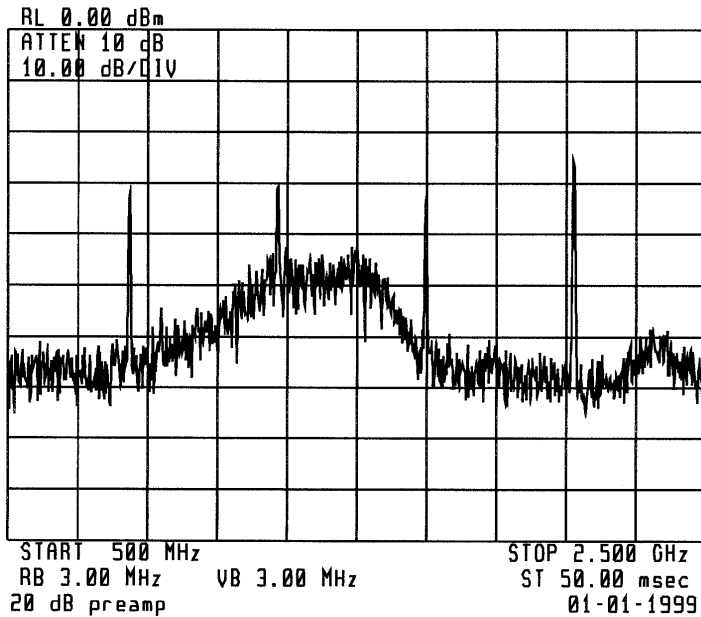
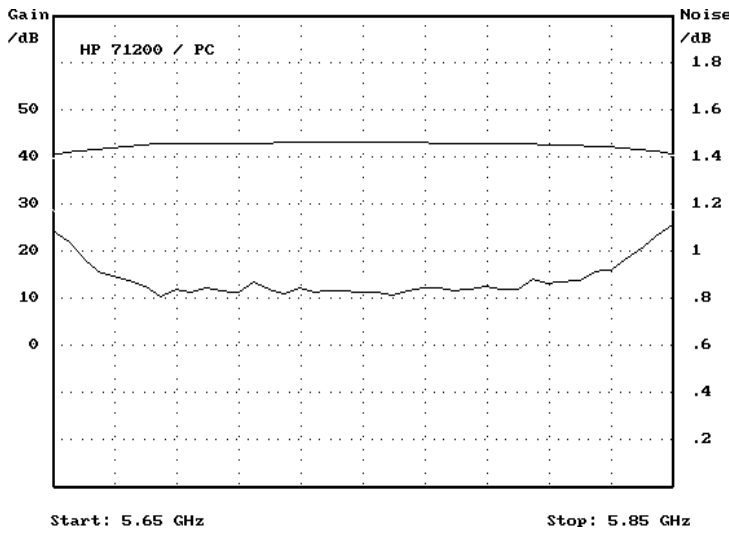

Fig. 2:  
Intermediate  
Frequency  
Spectrum of 5.7  
GHz Converter  
without Input  
Signal



**Fig. 3: Typical Curves for Amplification (top) and Noise Factor (bottom) of 5.7 GHz Converter**

short-circuit there for 5.7 GHz. For the intermediate frequency, reactive impedances arise on both sides of the diode which, together with the conduction component Lt 1 (approximately  $\lambda/4$  for 5.7 GHz) and the input circuit of IC 3 (stub 1, C 10) form a low-pass filter for the intermediate frequency. IC 3 acts merely as an intermediate frequency amplifier, through which the LO is additionally attenuated using stub 1.

A Colpitts circuit was selected for the SAW oscillator [1], which oscillates at 423.2 MHz.

The output spectrum of IC 4 contains a large number of harmonics [2], of which the 2.1 GHz signal is brought to approximately 3 mW by means of selective amplifier stages with IC 5. By increasing the R17b resistance (56 Ohms), the LO power can be reduced, if applicable, to optimise the noise.

Fig. 2 shows the intermediate frequency spectrum without an input signal. The external oscillator harmonics and the attenuation of LO obtained (2.1 GHz) can clearly be seen.

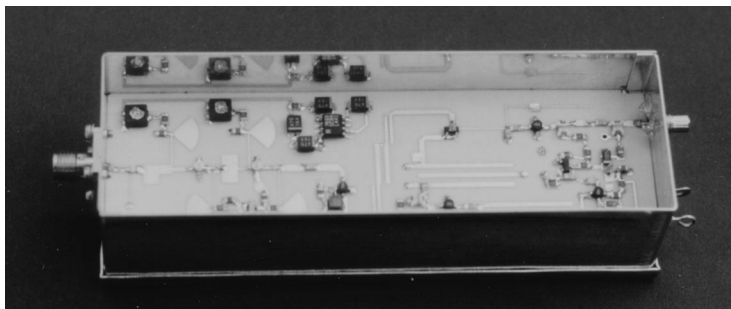

**Photo of ready to operate 5.7 GHz Converter; the Track Structures are very easily recognisable**

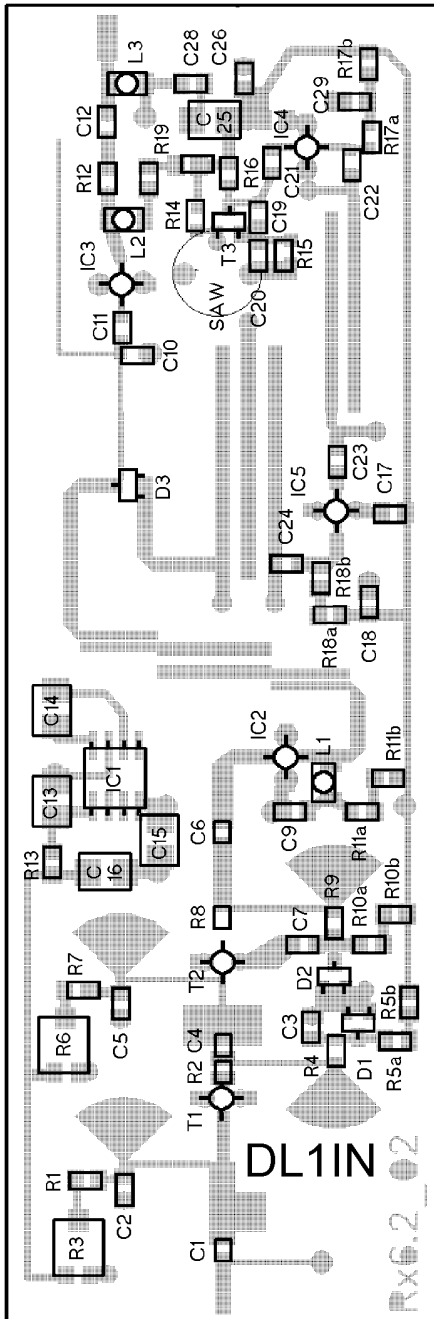

**Fig. 4: Components Plan with SMD Components on Foil Side**

Power for the converter can be supplied optionally through the intermediate frequency cable or separately through a 1 nF feedthrough capacitor. The suppressor diode D 4 is intended to provide protection against excessively high voltages and reverse connections.

8 V was selected as the internal operational voltage for the converter. The voltage multipliers for the ERA amplifier are each made up of two parallel SMD resistances, in order to attain the necessary rating.

The layout of the input stages has been optimised using the simulation software Silver Star from Eagleware, for minimal background noise and the largest possible amplification under conditions of absolute stability ( $K < 1$ ,  $B > 0$ ). Fig. 3 shows a typical curve for the circuits noise factor and transmission amplification.

### 3. ASSEMBLY

The printed circuit board, made from 0.5 mm. thick Rogers material RO4003, is soldered into a tinplate housing measuring 30 mm. x 37 mm. x 111 mm.. All the SMD components are on the foil side (Fig. 4).

Essentially, SMD format 0805 is used. Only on the drain connections of HEMT T1 and T2 was format 0402 needed for R2, R8 and C4, in order to attain the desired values for sensitivity and stability with the pre-set line lengths.

The SAW resonator and a wire strap to the voltage regulator are on the back of



the printed circuit board. The 8-V fixed voltage regulator is soldered directly to the housing for better heat dissipation.

Just a tip from personal experience because some of the SMD components for this circuit are especially small, this article is addressed only to experienced DIYers with a very steady hand.

This project can therefore also be obtained as a complete ready-to-operate module.

---

#### 4.

#### LITERATURE

---

[1] RF Monolithics data book

[2] DUBUS 2/98, P. 32

High-Order Frequency Multipliers using MMIC Devices

[3] Egelware Corporation, Genesys, version 6

Simulation Manual

[4] NEC data sheet NE 32584